

**ZZPERFORMANCE**

**Installation Instructions**  
Slingshot 74-Minute Turbo Kit  
2015-2019 Polaris Slingshot 2.4L



**Estimated Installation Time:** 2-4 hours

**Installation Difficulty:** 2/5

**Kit Contents:**

- Turbocharger
- Turbo manifold
- Downpipe
- Charge pipe assembly
- Intake tube
- Intake silicone
- Charge pipe silicones
- Air Filter
- Oil return plate
- Oil drain assembly
- Oil feed fitting and line
- Coolant feed line (silicone)
- Coolant return line (silicone)
- 5<sup>th</sup> injector and boost harness
- Fresh air line
- Stainless t-bolt clamps
- Worm clamps
- V-band clamps

**Tools Needed:**

- Open or box end wrenches, 10 to 22mm
- Scraeder valve removal tool
- Painter's tape
- Socket set, 8mm up
- Adjustable wrench or AN wrenches
- Allen wrench set or Allen sockets
- Flat head screwdriver
- Ratchet
- Extensions

***Installation Instructions Note: The kit pictured in these installation instructions is a prototype kit, so some components may vary and/or look different than what you have received. If you have any questions during or after your install, please reach out to [Customerservice@zzperformance.com](mailto:Customerservice@zzperformance.com)***



### STEP ONE: Remove stock intake tube and airbox.

- Unplug the air intake temperature sensor on the intake tube
- Remove the fresh air inlet hose that runs from the intake tube to the valve cover
- Use a flathead or socket to loosen and remove the clamps on the intake tube to the airbox and throttle body.
- Remove intake tube
- There are three screws holding the stock airbox to the frame. Loosen and remove those and remove stock airbox.

### STEP TWO: Remove throttle body

- Undo throttle body connector from side of throttle body
- Remove the 4 bolts that hold the throttle body to the intake manifold and set throttle body to the side

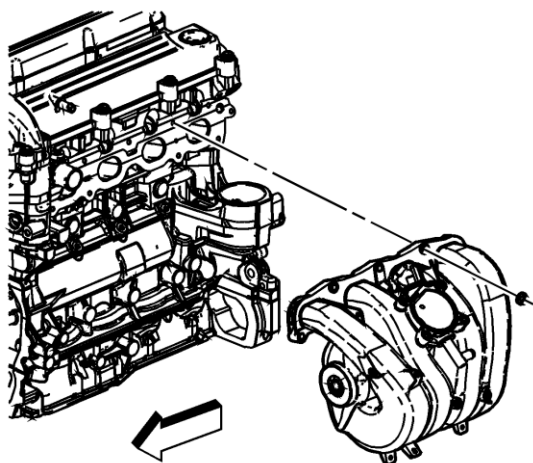
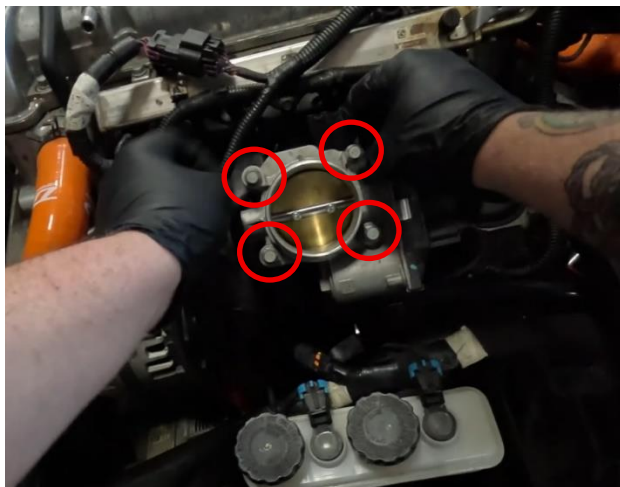

### STEP THREE: Remove intake manifold

- Unplug MAP sensor connector located above throttle body location
- Remove hose from fitting that runs to the EVAP purge solenoid (pinch and pull up).
- Remove the 7 bolts holding the intake manifold to the head.
- Remove intake manifold. And set aside
- Tape up intake ports (if desired) to keep debris out of intake ports.

#### STEP FOUR: Plug port in head

- Our kit includes a small stainless steel plug that is individually bagged.
- Since we don't want to be boosting the crankcase, that's what the plug is for.
- Insert plug into circled hole on the right.
- Use a hammer to tap the plug in until it sits flush on the shoulder.

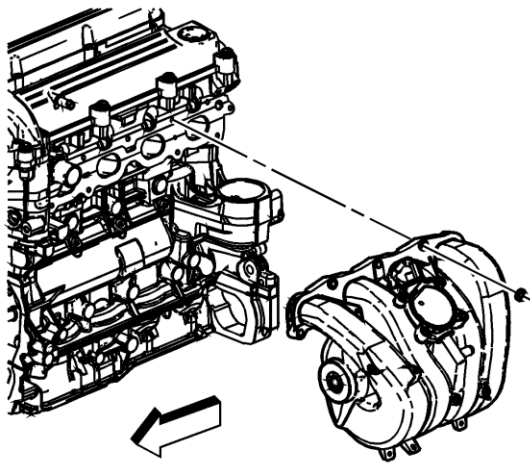
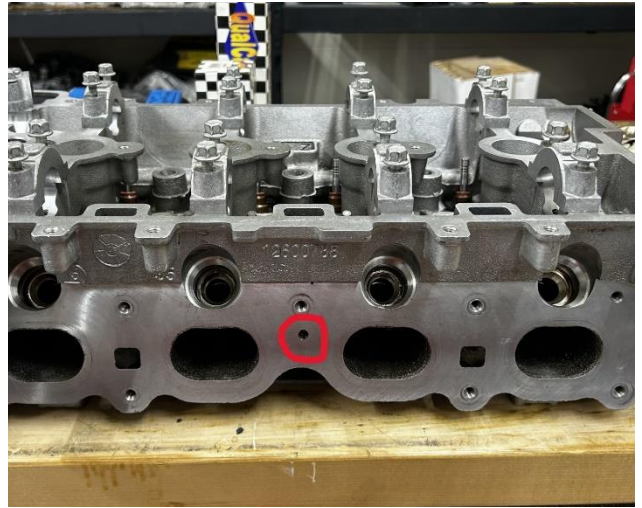

#### STEP FIVE: Reinstall Intake manifold and components

- Reinstall intake manifold and tighten bolts
- Reinstall throttle body
- Plug MAP sensor back in
- Leave EVAP line disconnected from intake manifold, we will be using that fitting for the boost reference later. You can fully remove the EVAP line as the Slingshot does not have an EVAP system.

#### STEP SIX: Begin removal of stock exhaust components

- Unplug primary O2 sensor on exhaust manifold.
- You may find it helpful to loosen and remove the O2 sensor while it's still attached to the engine. Set O2 sensor aside.
- Loosen and remove the 3 bolts holding the exhaust manifold to the muffler assembly.
- Loosen and remove the 10 nuts bolting the manifold to the head.
- Remove exhaust manifold.

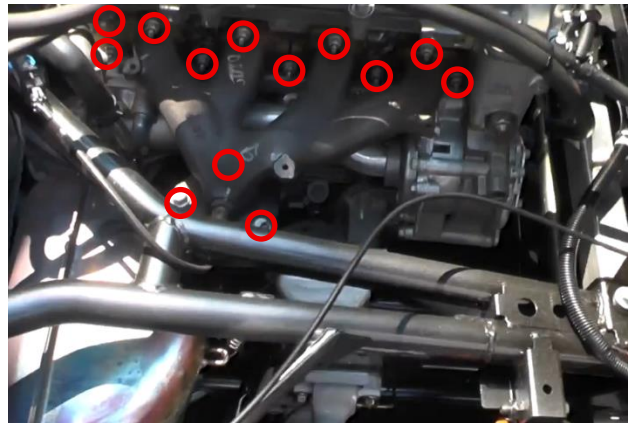

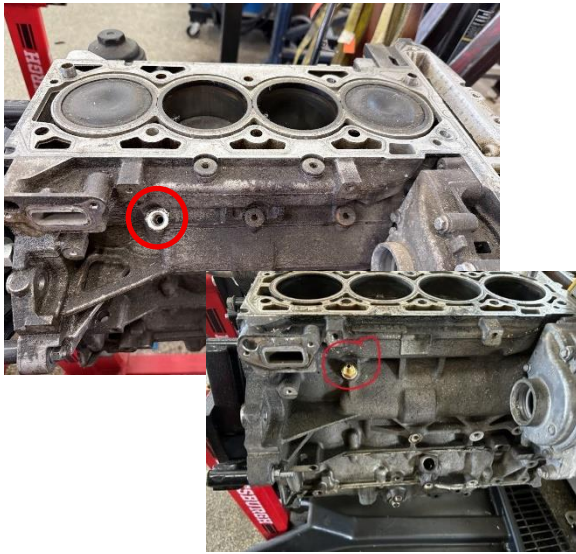

### STEP SEVEN: Install oil feed fitting

- With the exhaust manifold off you should now be able to locate the oil galley plugs located just behind the coolant crossover tube.
- Using a 6mm allen key or socket, loosen and remove the galley plug closest to the thermostat housing (circled to the left).
- Install brass oil feed fitting into the block, we recommend some thread sealant on the block side.
- Tighten to 15 ft/lbs, do not overtighten
- Install oil feed line onto fitting, this is longer of the two braided stainless lines. The straight fitting goes on the block side, the 90° fitting will go onto the turbo once installed.
- Tighten line to fitting and pull line over by the frame rail

### STEP EIGHT: Install ZP turbo manifold

- Reinstall the exhaust manifold gasket
- Place turbo manifold onto studs and start to tighten down nuts
- Follow the sequence found on the right and torque nuts to 10 ft/lbs
- Tighten the turbo manifold nuts a second time to 10 ft/lbs

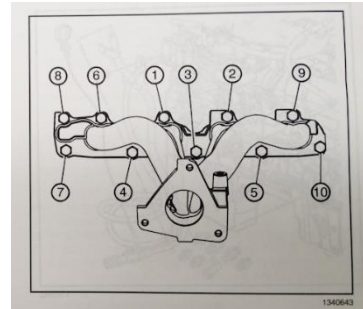

### STEP NINE: Install turbo downpipe

- Place cast turbo downpipe/O2 housing onto the stock muffler.
- Install and tighten the 3 bolts holding the downpipe to the muffler.
- Reinstall O2 sensor into downpipe and tighten. Do not connect the O2 sensor to the housing yet.
- Loosen and place v-band clamps onto the rings, larger on the downpipe and smaller on the turbo manifold.

### STEP TEN: Install turbo oil return plate

- On the front cover of the engine there is a plate opposite the water pump held on by 4 bolts (pictured to the right).
- Remove stock plate
- Install ZZP oil return plate as pictured. Verify that O-ring is fully in the groove on the back side that meets the engine.
- Tighten bolts

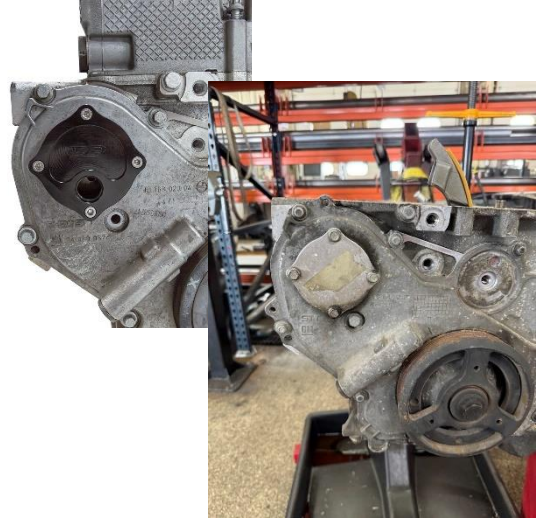

### STEP ELEVEN: Install turbo oil drain

- Before placing the turbo onto the car you'll want to pre-install the turbo drain line onto the turbo.
- The grey hose with two black fittings is your turbo drain line.
- The longer of the two 90° fittings will attach to the drain on the turbocharger.
- Install and tighten the drain hose to the turbo
- You may find it helpful to loosen the worm drive clamp on the turbo side of the hose to allow the hose to rotate.

### STEP TWELVE: Install Turbo

- Once the drain line has been installed, you can drop the turbo into place
- Place the turbo onto the v-band connections
- Once in place and the v-band clamps are over both sides of each ring begin to tighten the clamps
- Before fully tightening clamps ensure that each face of the rings are flush with each other and the clamps are even on the rings.
- Tighten the clamps fully.
- Once turbo is in place, tighten the oil drain to front cover return plate.
- You may need to slightly twist the grey hose to get the fitting flush on the return plate.
- Fully tighten the fitting on the hose to the return plate. Tighten worm clamps if loosened in process.



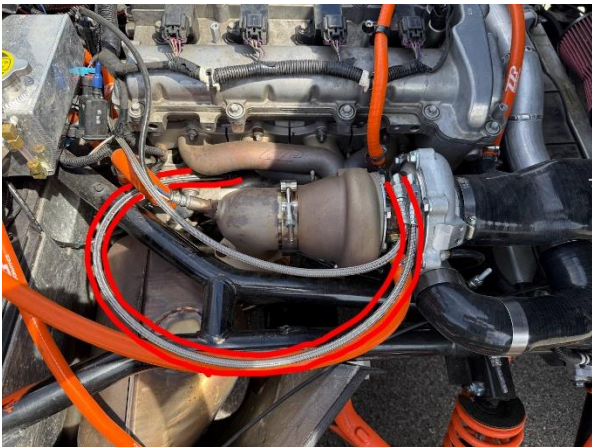

### STEP THIRTEEN: Install turbo feed line

- Once the turbo is fully in place we'll install the turbo feed line.
- Take your line coming from the oil feed fitting on the block and route it as pictured on the left.
- We include a longer line to keep it away from direct heat.
- Feel free to lightly zip tie the line to the frame for a cleaner installation.
- Tighten 90° fitting onto turbo and ensure fitting is tight onto the line.

### STEP FOURTEEN: Install couplers and charge pipe

- The standard 90° coupler will go onto the turbo outlet. Slide appropriate t-bolt clamps onto the coupler. The longer, smaller diameter side will slide onto the turbo outlet. Do not tighten clamps
- The other flat 90° coupler will go onto the throttle body. Slide appropriate t-bolt clamps onto the coupler. Install onto throttle body. Do not tighten clamps.
- Slide charge pipe assembly into couplers. The injector and sensor will go on the intake manifold side.
- Using the two provided silver M8 bolts, tighten the charge pipe to the engine.
- Once secured and in both couplers tighten all t-bolt clamps.

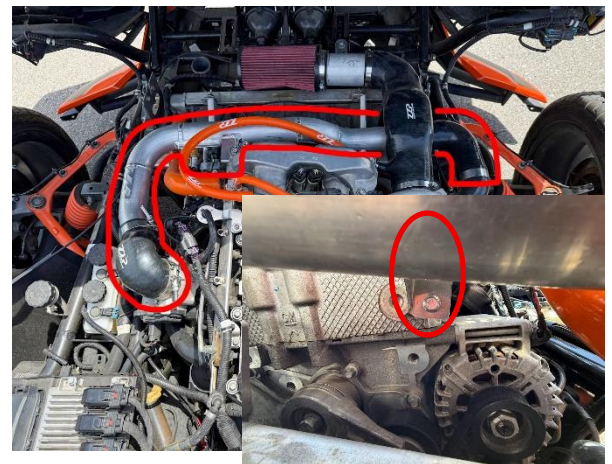

### STEP FIFTEEN: Install turbo intake

- Install large flat silicone coupler onto turbo inlet with appropriate worm drive clamps, leave loose.
- Insert powdercoated tube with bracket into silicone, bracket goes towards the front of the vehicle and will bolt to frame bracket.
- 2015 and 2016 models will take the small black spacer and place it under the bracket to space it up. 2017-2019 model years do not need the spacer. Location circled on the left.
- Insert M6 bolt and washer and tighten to secure intake tube to frame. Tighten clamps to turbo inlet and intake tube.
- Place filter on intake tube and tighten clamp.

### STEP SIXTEEN: Install 5<sup>th</sup> injector/boost harness

- Install wiring harness bracket to front fuel rail bracket using stock bolt. Vacuum line will face upward.
- Connect vacuum line using 5/16" quick connect to the fitting on the intake manifold.
- Connect the rest of the harness. Start with long portion which will run to the O2 harness. Plug O2 sensor into harness, then plug our harness into stock wiring harness where the O2 would connect.
- Unplug Injector #1 connector from injector (front most injector). That stock connector will plug into the ZZP harness. Then connect to injector #1 with the ZZP harness. The final connector will plug into the additional injector on the charge pipe.
- See diagram in step 17.

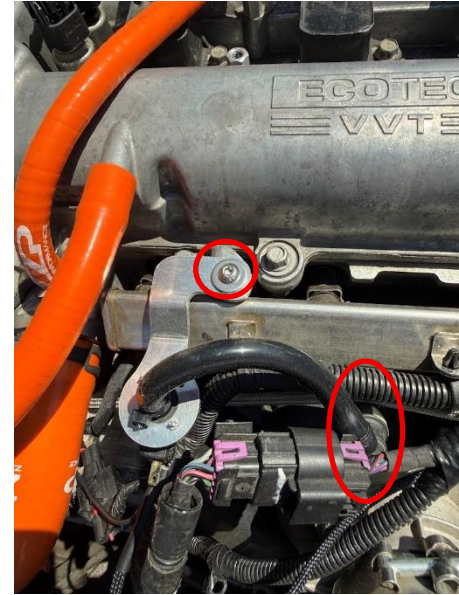

### STEP SEVENTEEN: Wiring harness diagram

- See diagram on the left for proper connections
- Once fully connected, tuck wiring harness away and zip tie to secure if desired.
- Connect stock intake temperature sensor connector to sensor on charge pipe assembly.

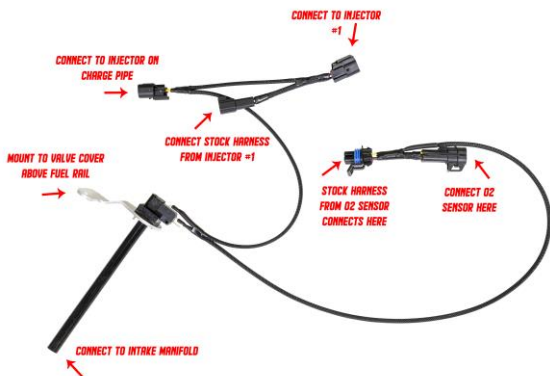

### STEP EIGHTEEN: Install 5<sup>th</sup> injector fuel line

- We will be tapping into the Schrader valve on the fuel rail for fuel supply.
- Release pressure from rail by depressing the valve with a small flathead or pick, using a rag to catch the fuel.
- Use a Schrader valve removal tool/valve core remover to pull the valve out of the rail.
- The second smaller braided line will be our fuel line. Attach one of the provided 90° fittings to one end and secure to the rail.
- Attach the other end to the fitting on the charge pipe assembly.
- Tighten both sides.

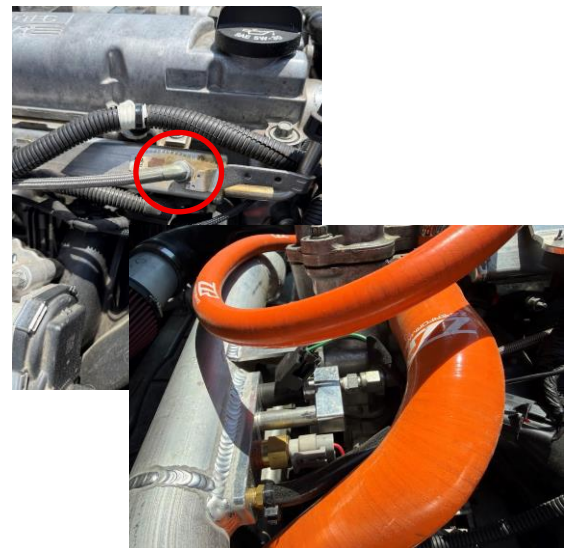

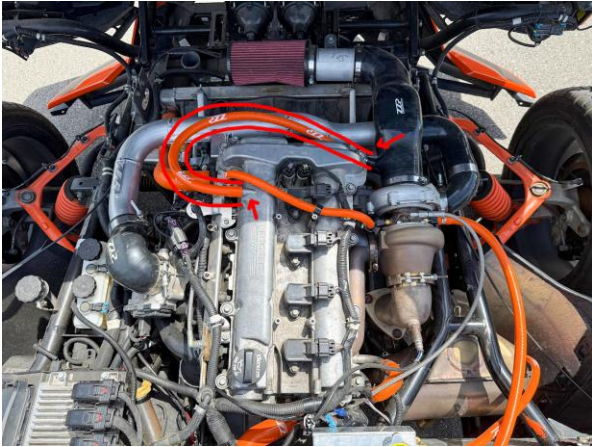

### STEP NINETEEN: Install fresh air line

- Use the included black silicone 3/8" line to connect the fresh air fitting on the valve cover to the silver fitting on the silicone intake tube.
- Tighten using provided worm drive clamps.

### STEP TWENTY: Verify connections

- Verify all of your connections are tight in all locations. Double check fuel line connection, oil feed and return line connection.
- Verify all t-bolt clamps and worm drive clamps are tight.
- Verify V-band clamps on turbo assembly.
- **Verify that you have premium 91 or 93 octane in the tank before first startup.**

### STEP TWENTY-ONE: Start up and enjoy!

- Upon first start up look around the engine bay and verify that there are no leaks, specifically on the fuel lines and oil lines.
- You may notice some smoke coming from the turbo manifold/turbo/downpipe. This is normal as the manufacturing oils burn off.
- Take your Sling for your first drive and enjoy the extra power and turbo noises!